

## DC-DC CONVERTER HPBC20-W/T

RAILWAY CONVERTER.

### FOR DIN RAIL MOUNTING



### HIGHLIGHTS

- + Output Power up to 10 Watts\*
- + Efficiency up to 85%
- + Ultra Wide Input Range
- + Wide Temperature Range
- + Hold-up-time > 10ms
- + RoHS compliance
- + According to EN50155

### INPUT

Input Voltage Nominal	24, 36, 48, 72 and 110 VDC
Input Voltage Operating	16,8-137,5 VDC
Input Voltage Range	14,4-154 VDC ( $t \leq 1,0$ sec.)
No Load Input Current	See table page 2

### OUTPUT

Output Voltage	5,1 V
Initial Set Accuracy	< 2 % (no load)
Minimum Load	No minimum load
Short circuit	Continuous short circuit proof
Line Regulation	< 0,5 %
Load Regulation	< 2 % (0% - 100% load)
Ripple & Noise	< 2 % pk-pk, 20 MHz bandwidth
Start Time	< 900 ms
Max. Output Capacitance	1000 $\mu$ F $\times$ $I_{out\ nom}$
Temperature Coefficient	< 0.01 %/°C

### FEATURES

Reverse Polarity Protection	Max.160 V
Hold-up-time	> 10 ms at 20 W load

### PROTECTION

Output Over Voltage Protection (OVP)	110-130 % $V_{out\ nom}$ ***
Over Current Protection (OCP)	See table page 2
Over Temperature Protection (OTP)	Shutdown at +110-115°C PCB-temp. with about 5°C hysteresis and auto recovery.

### GENERAL

Product Standard	EN 50155:2007
Isolation	2200 VDC Input to Output 1500 VDC Input to Earth (PE) 710 VDC Output to Earth (PE)
Switching Frequency	Typ. 120 kHz
Dimensions [mm]	64 x 73,5 x 105,4
Weight	approx. 300 g
MTBF	950.000 h acc. MIL-HDBK-217F (GB, 45°)

### ENVIRONMENTAL

Operating Ambient Temp.	-40°C to +85°C*
Storage Temperature	-55°C to +100°C
Vibration / Shock / Bump	EN 61373:1999, Cat. 1B

### EMC

EMC Standard	EN 50121-3-2:2006
Conducted Emissions	EN 50121-3-2:2006**
Radiated Emissions	EN 55011:2007+A2:2007, Class A**
ESD Immunity	EN 61000-4-2:2009, level 3 (6kV/8kV), Criteria A
Burst	EN 61000-4-4:2004, level 3 (2kV), Criteria A
Surge	EN 50121-3-2:2006, line to line $\pm$ 1kV, 42R, and line to case $\pm$ 2kV, 42R, Criteria A
Conducted Immunity	EN 61000-4-6:2007+A1:2001, level 3 (10V), Criteria A
Radiated Immunity	EN 61000-4-3:2006, 20V/m, Criteria A

\* +70°C continuously, +85°C max. 10 minutes. Natural convection should be assured.

\*\* In built-in condition the devices may show different EMC properties.

\*\*\* At 4,7  $V_{out}$  115-140 %  $V_{out\ nom}$

# TECHNICAL DATA

For  $T_{amb} = 25^{\circ}C$ ,  $V_{in nom}$ ,  $I_{out nom}$  unless otherwise specified

## SPECIFICATION Input 14,4 - 154 VDC

TYPE		HPBC20-W/T					
ORDER NUMBER		87 92 08 0011 4					
CHARACTERISTIC		Unit					
INPUT	Input Voltage Nominal	V	24	36	48	72	110
	Input Voltage Range	V	14,4...36	21,6...51	28,8...67,2	43,2...101	66...154
	Under Voltage Turn-on	V	<15,0...16,8				
	Under Voltage Turn-off	V	<12,0...14,4 (14,4V < $V_{in}$ < 16,8V at $t > 1$ sec.)				
	Input Current @ Full Load	A	0,5	0,33	0,25	0,17	0,11
	Input Current @ No Load	A	0,09	0,06	0,05	0,03	0,02
	Recommended External Fuse	A	2,0				
OUTPUT	Output Voltage Nominal	V	5,1				
	Output Current Nominal	A	2,0				
	Output Power	W	10				
	Efficiency @ Full Load (typical)	%	83	84	84	84,5	87
	Output Current limit	A	4,0...5,0				
	Short Circuit Current (typical)		8 (pulse approx. 3Hz)*				
	Transient Response 25 % / 75 % Load Step Recovery Time < 1 ms	mV	±150				

\*Peak current pulsating

# TECHNICAL DATA

For  $T_{amb} = 25^{\circ}\text{C}$ ,  $V_{in\ nom}$ ,  $I_{out\ nom}$  unless otherwise specified

## MECHANICAL DETAILS

1. Dimensions are in mm
2. Unless otherwise specified, general tolerances  $\pm 0,5$  are for values in brackets (XX)  
Values not in brackets are according to ISO-2768-1m

Coating: Lackwerke Peters ELPEGUARD SL 1307-FLZ/2

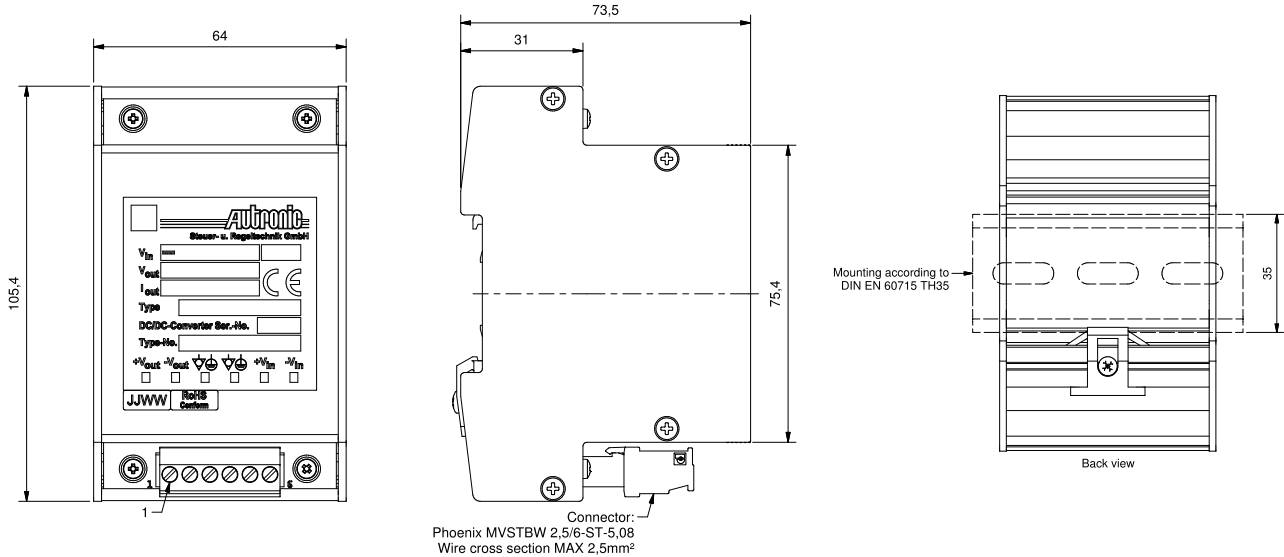

PCB: UL94-V0, EN45545-2:2016-02 Pending

## PINNING

Pin	Function
X1-1	$+V_{out}$
X1-2	$-V_{out}$
X1-3	PE
X1-4	PE
X1-5	$+V_{in}$
X1-6	$-V_{in}$

## NOTES

Installation instructions:

The converters have to be installed according to the guidelines currently in force, like other open electronic component assemblies. Attention must be paid to sufficient ventilation, carry off heat, fastening and protection against accidental contact. Plug in not under voltage if converter connected parallel or in series.

Fault protection: For input protection a time-lag fuse corresponding to IEC 60127-2 must be installed. For recommended rating of the fuse refer to specification table above. Pay attention on sufficient current source in case of short circuit.

## BLOCK DIAGRAM

